

Name

LEVEL 3

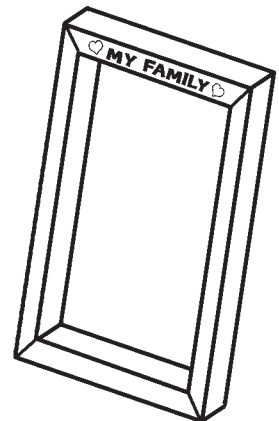

Name

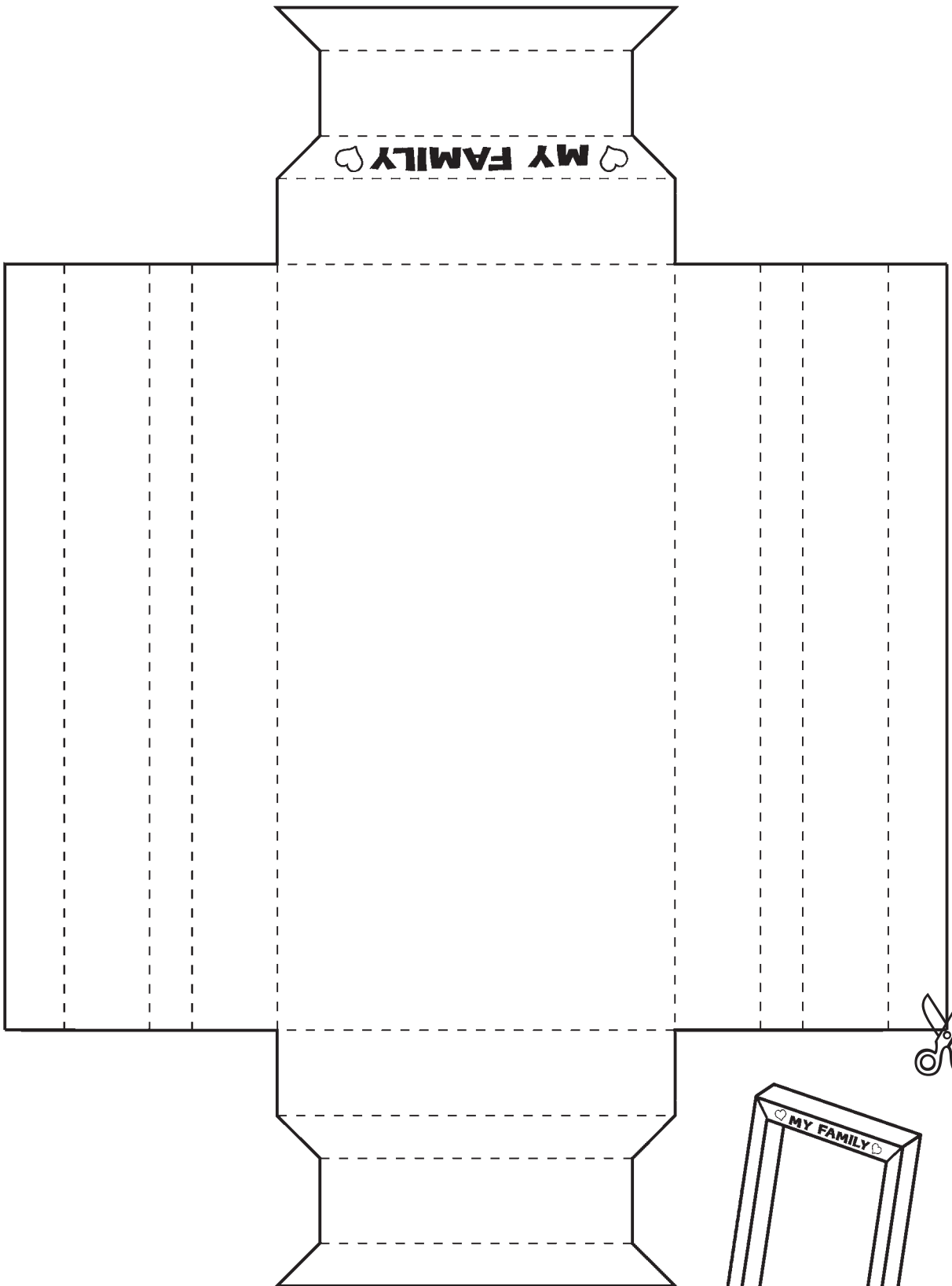
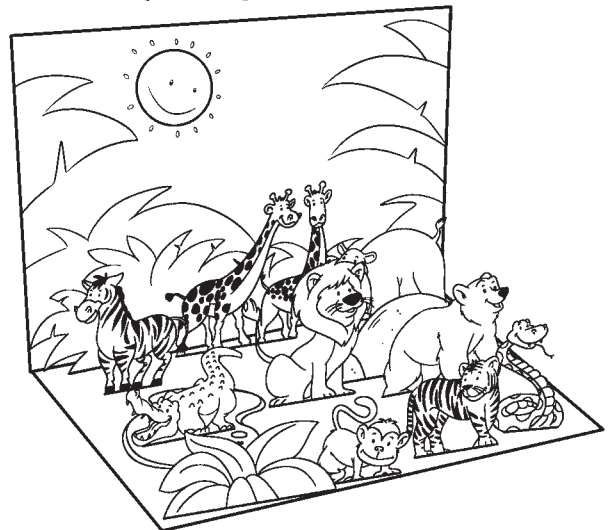
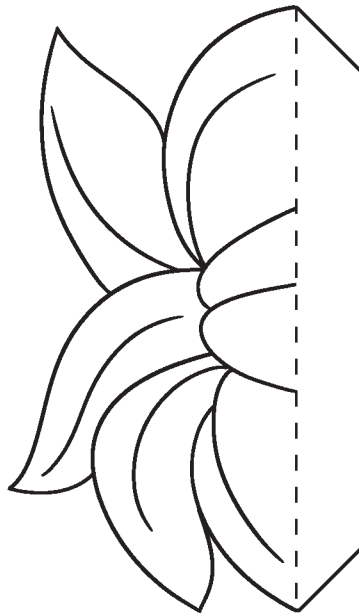
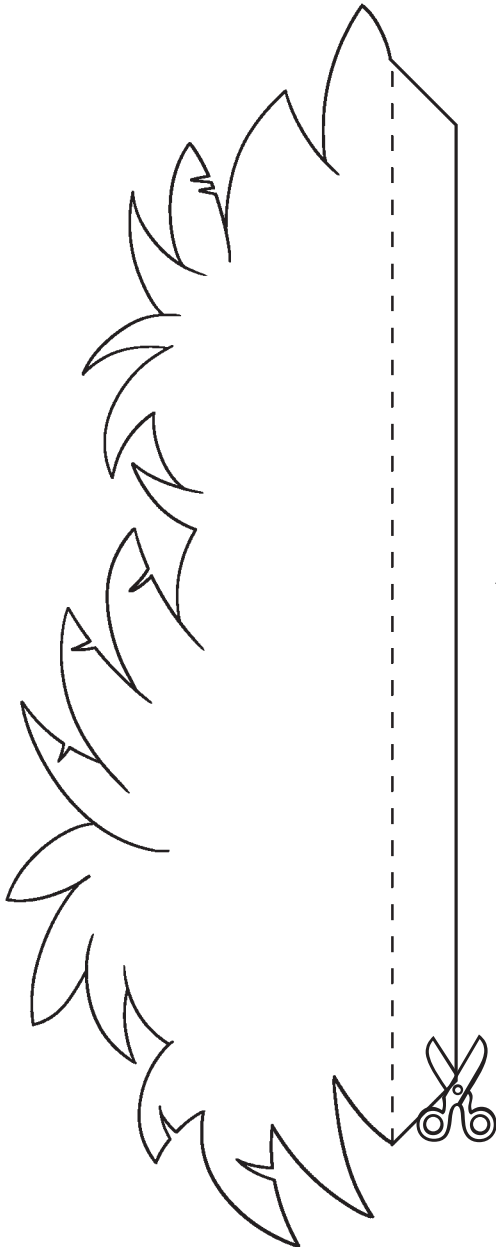
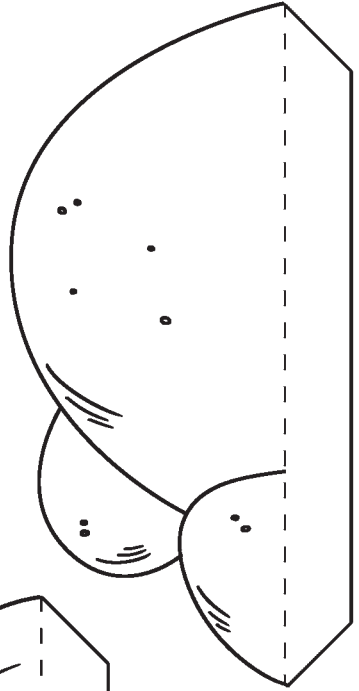
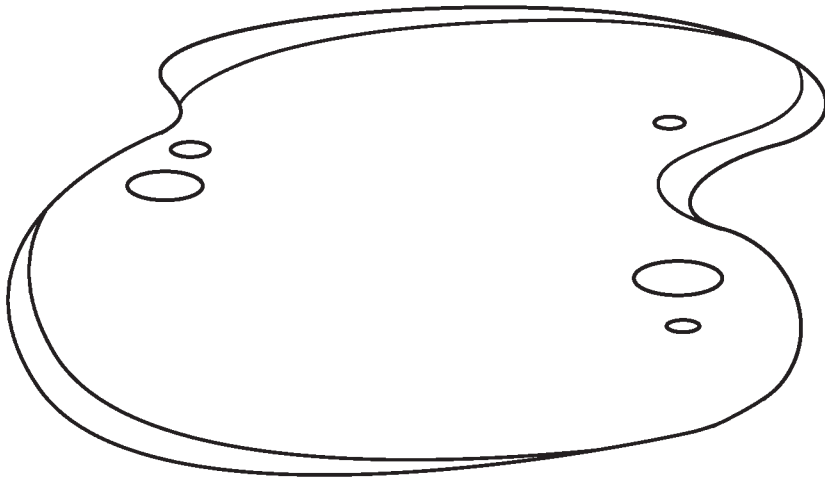

Name

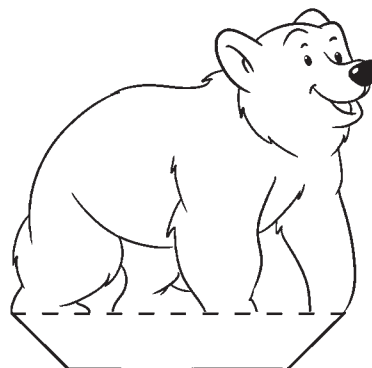
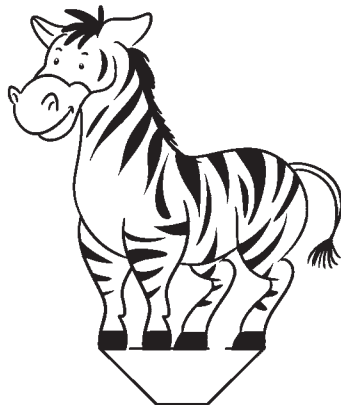
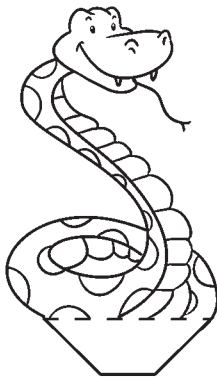
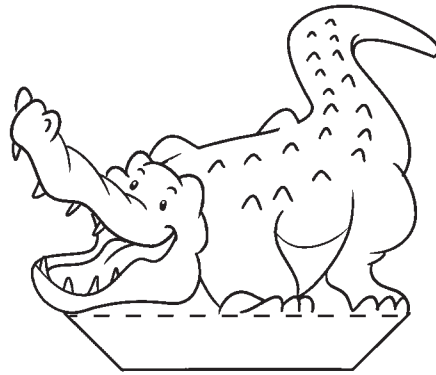
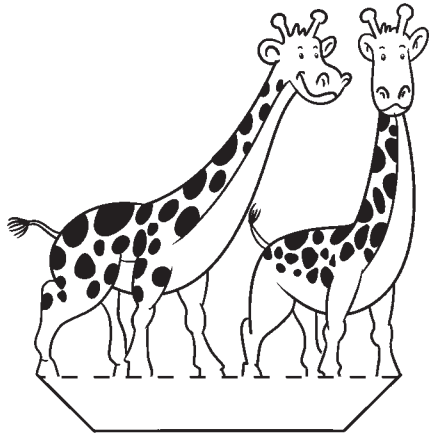
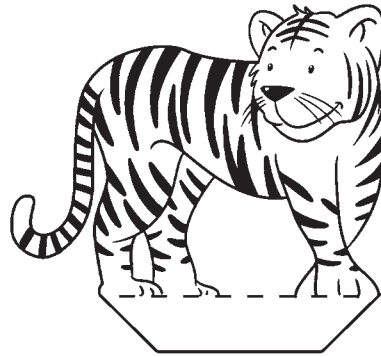
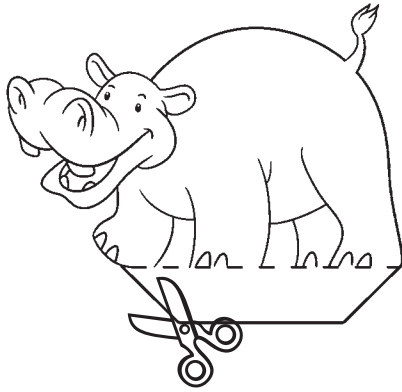

LEVEL 3

MY OPPOSITES LADDER

Name

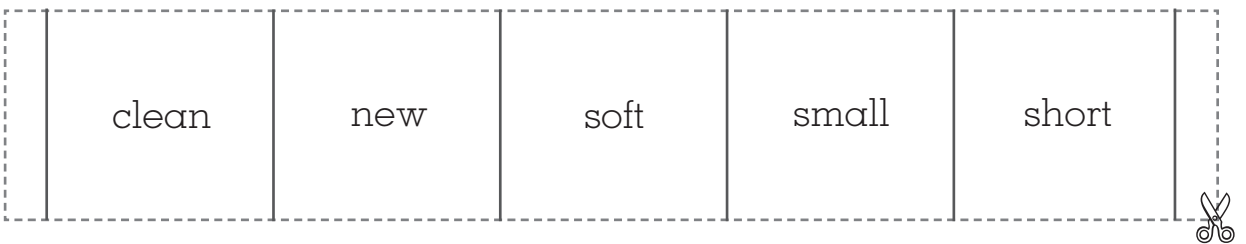
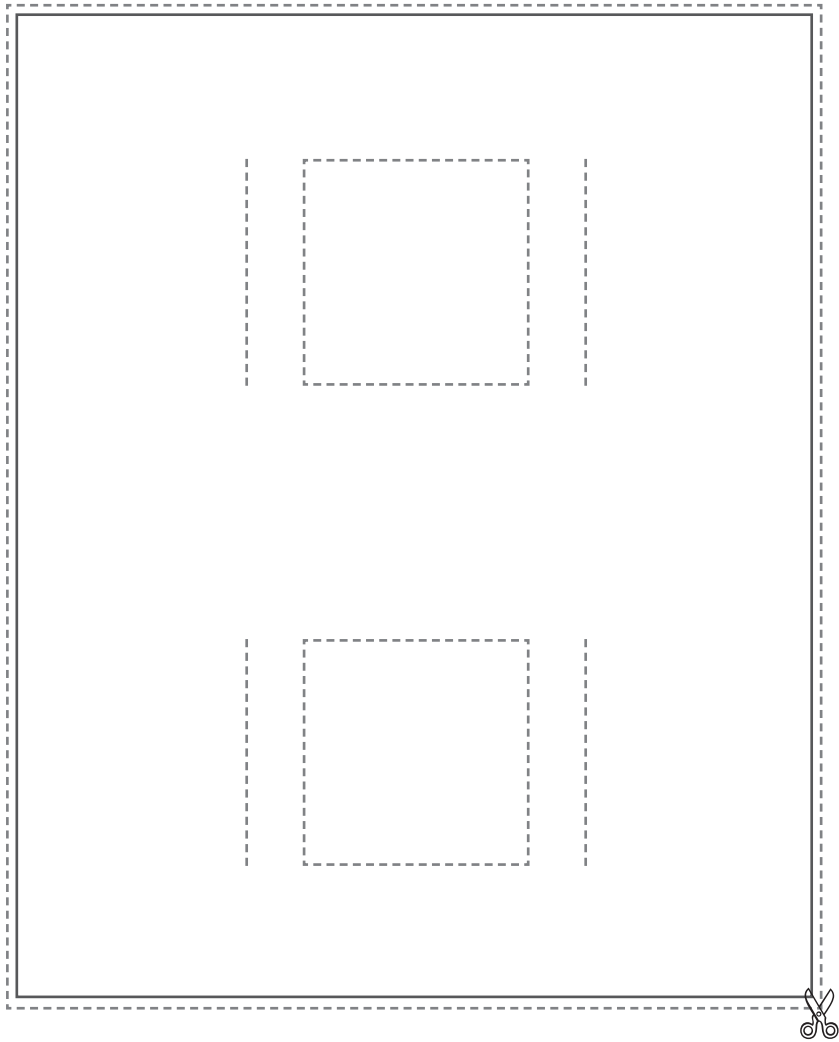

Name

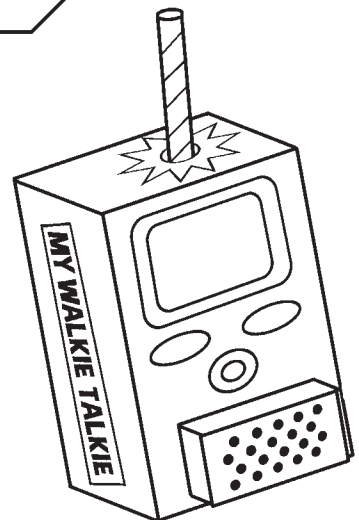
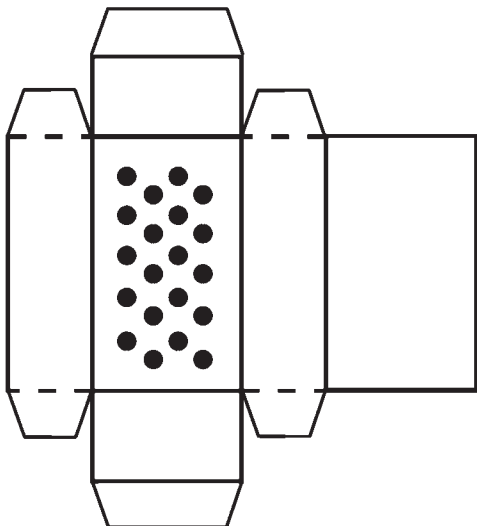
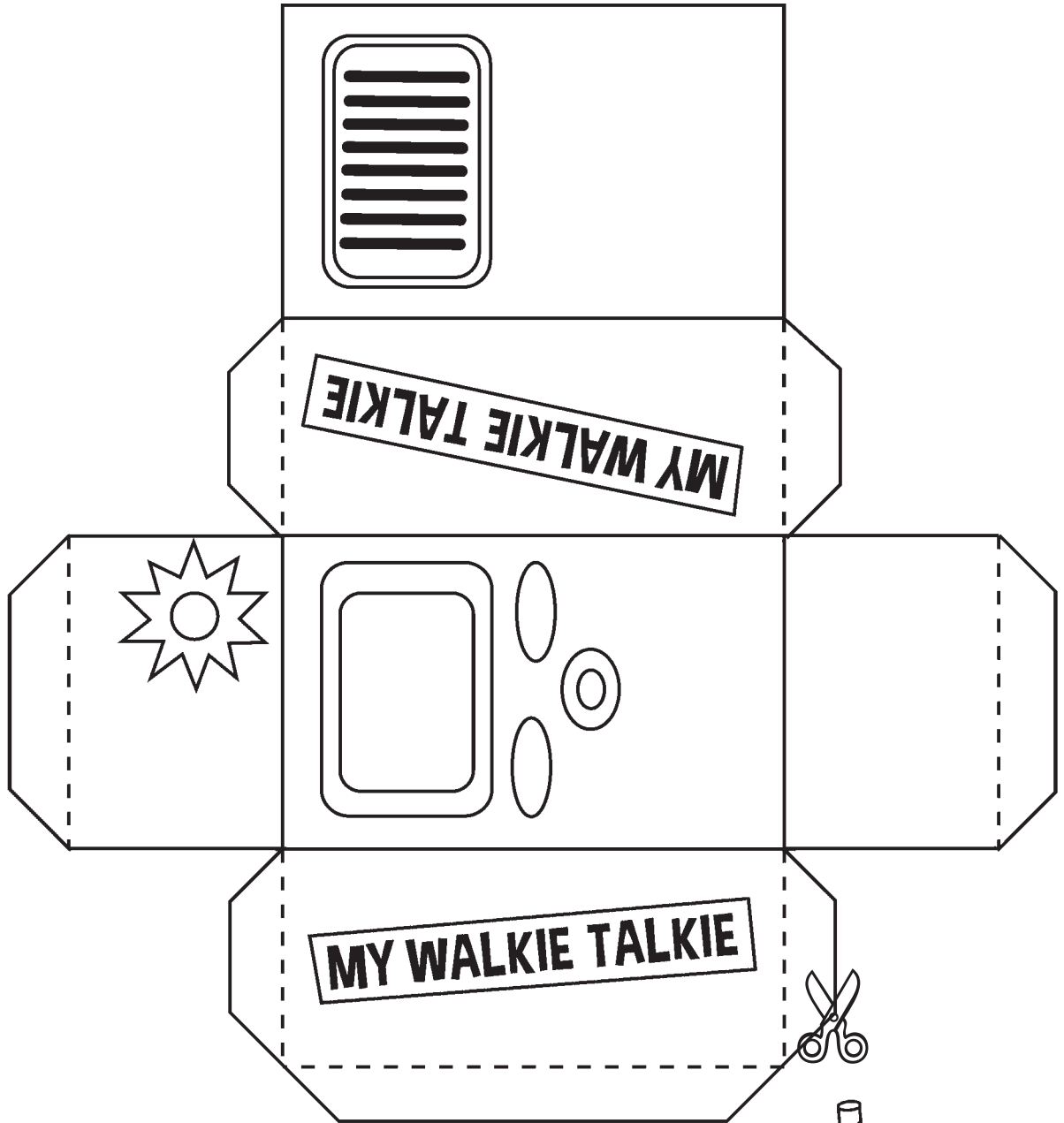

LEVEL 3

Name

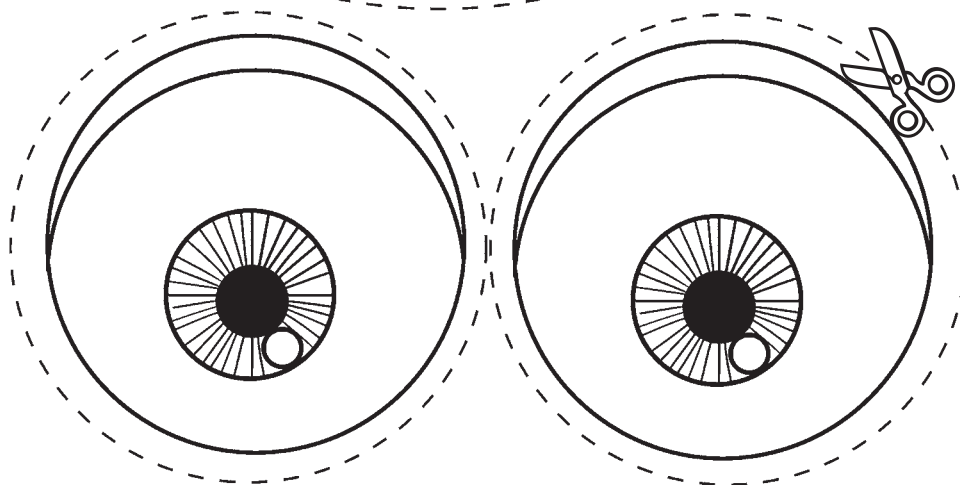
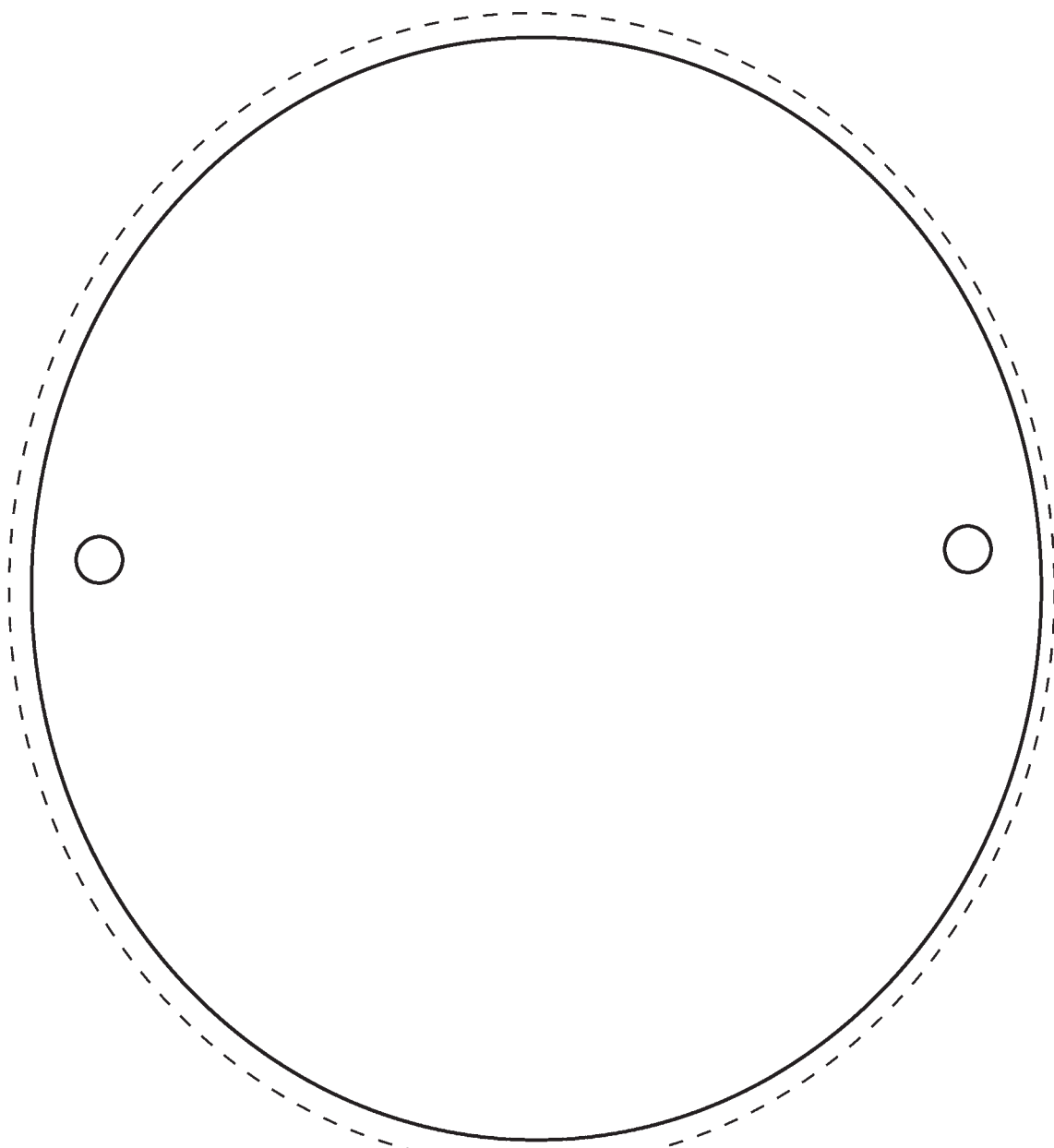

Name

LEVEL 3

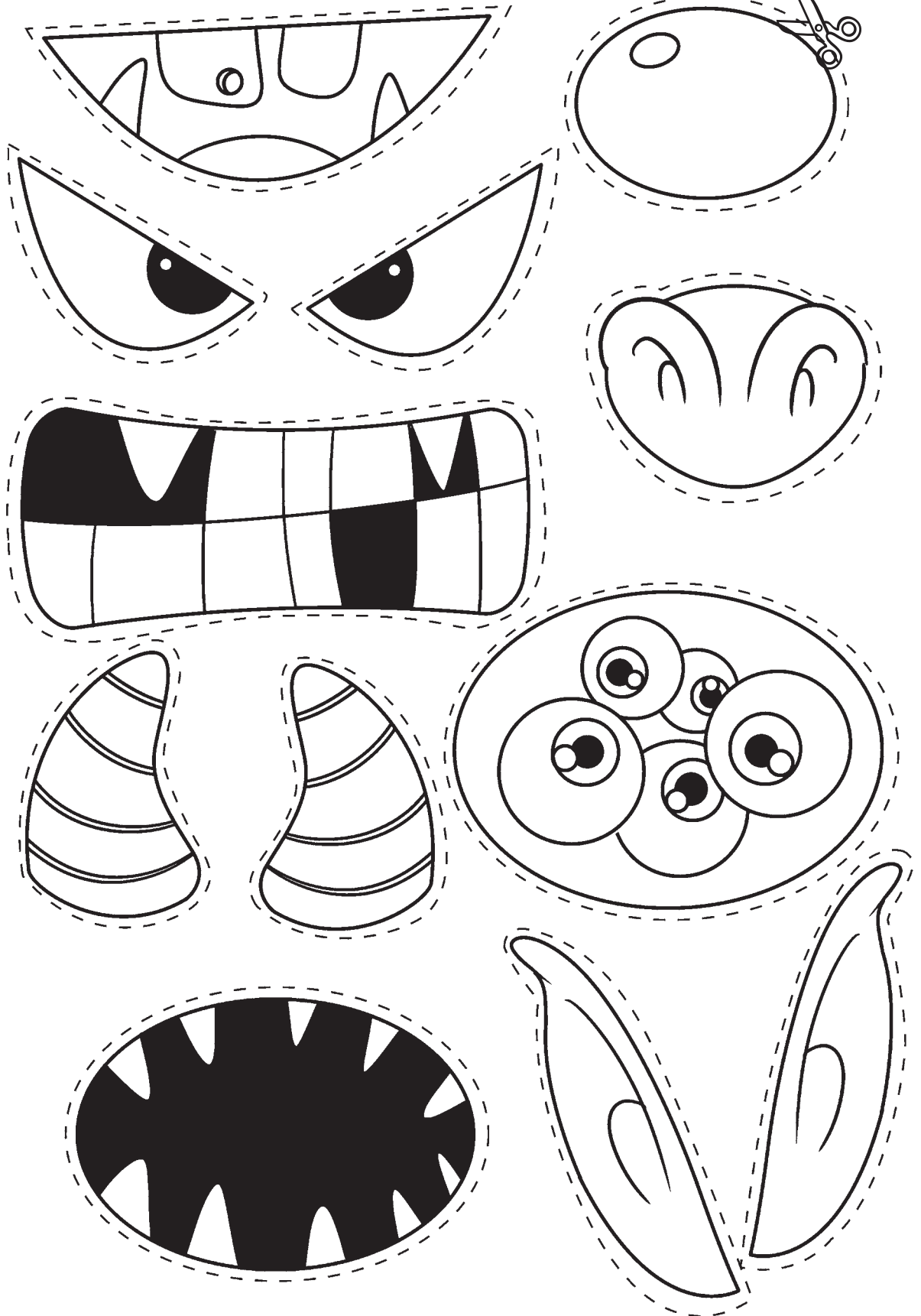

1 Colora e ritaglia il tuo distintivo da "Top Secret detective".



2 Colora, ritaglia e appendi alla tua porta.

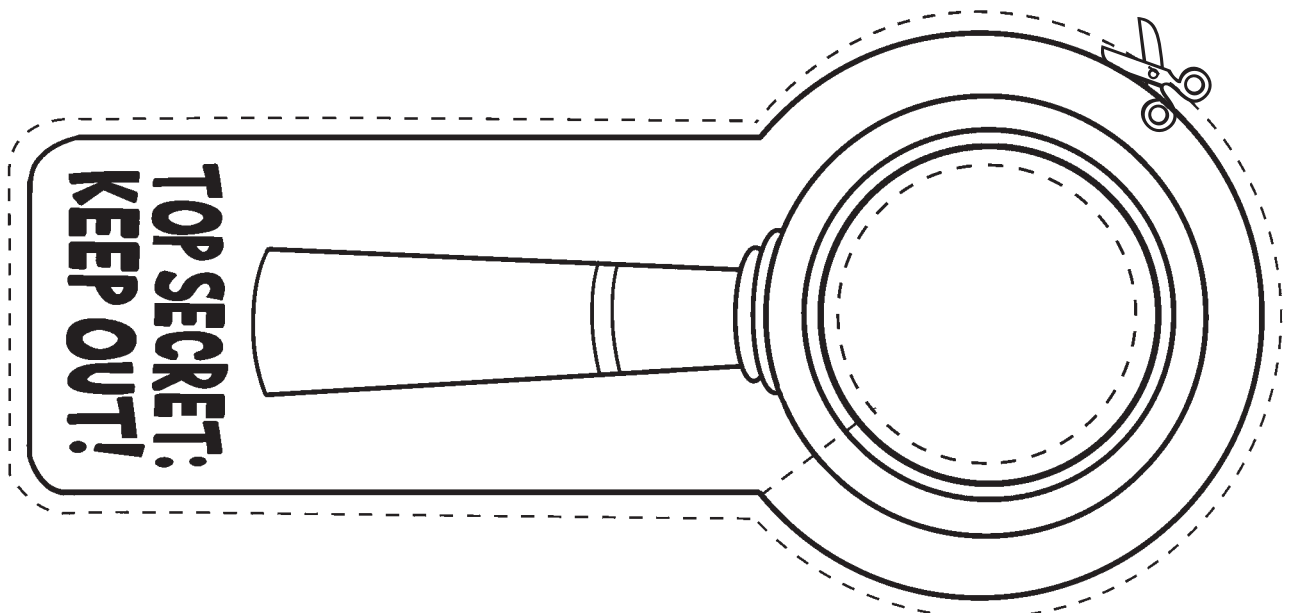

1 Osserva la foto che Tom ha scattato alla sua famiglia. Poi completa le frasi con *he, she* oppure *it* e numera i componenti.

- 1 is my grandfather. 5 is my dog.
 2 is my sister. 6 is my mother.
 3 is my grandmother. 7 is my brother.
 4 is my father.

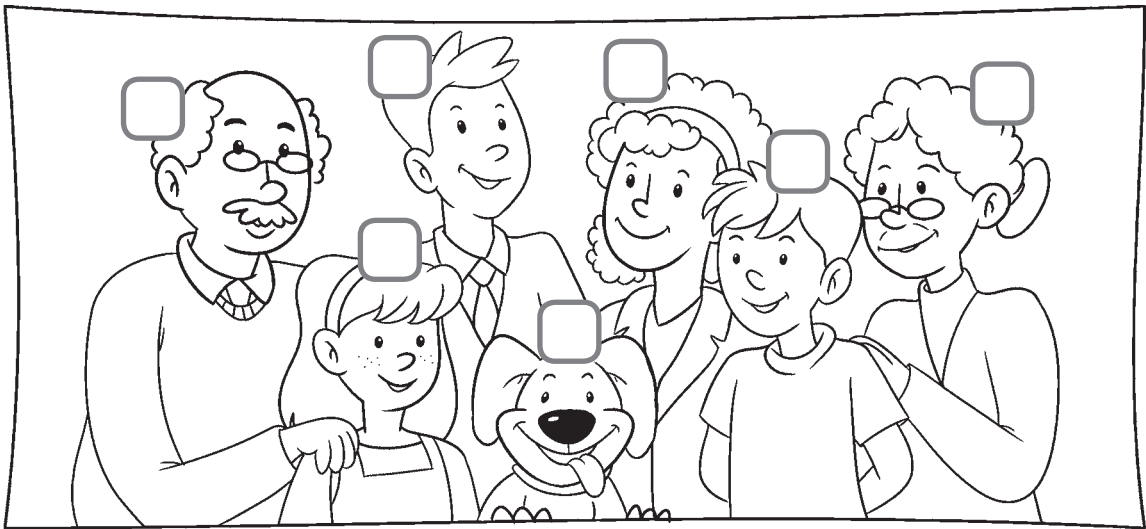

2 Immagina di essere Tom e rispondi alle domande.



- 1** Is he your uncle? **2** Is she your sister? **3** Is she your aunt?

.....

.....

.....



- 4** Is he your brother? **5** Is she your cousin? **6** Is he your father?

.....

.....

.....

1 Copia le parole sotto i disegni giusti.

1



giraffe
giraffes

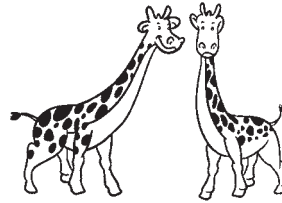

.....

.....

2

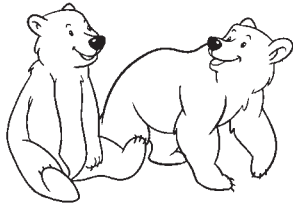

bear
bears

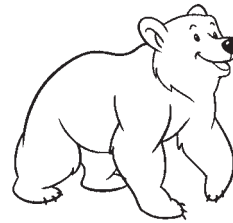

.....

.....

3



tiger
tigers



.....

.....

4



dog
dogs

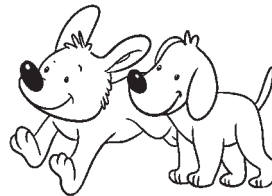

.....

.....

2 Scrivi le seguenti parole al plurale.

1 pen

6 girl

2 car

7 book

3 ruler

8 doll

4 school

9 scooter

5 boy

10 bike

OPPOSITES

Name

Completa i fumetti con la corretta forma del verbo essere all'affermativo o al negativo.

1 I happy.
I sad.



2 You tall.
You short.



3 It new.
It old.



4 He dirty.
He clean.



5 She thin.
She fat.



6 They soft.
They hard.



7 We young.
We old.



8 You big.
You small.

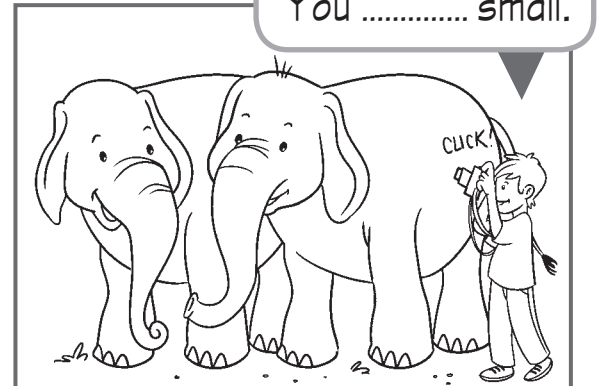

LEVEL 3

Colora le *game cards* a piacere. Incollale su un cartoncino e ritagliale.



HAVE GOT AND HAS GOT

Name

1 Completa i fumetti con *have got* oppure *haven't got*.

I a mobile phone and a laptop.
 I a video camera.



I a bike and a scooter.
 I a skateboard.



2 Osserva i disegni dell'esercizio precedente e completa con *has got* oppure *hasn't got*.

- 1 He a cat.
- 2 She a video camera.
- 3 He a skateboard.
- 4 She a brother.
- 5 He a scooter.

3 Rispondi alle domande.

- 1 Has he got a skateboard?
- 2 Has she got a camera?
- 3 Has he got a bike?

LEVEL 3

Completa il tuo albero genealogico.

We are a family

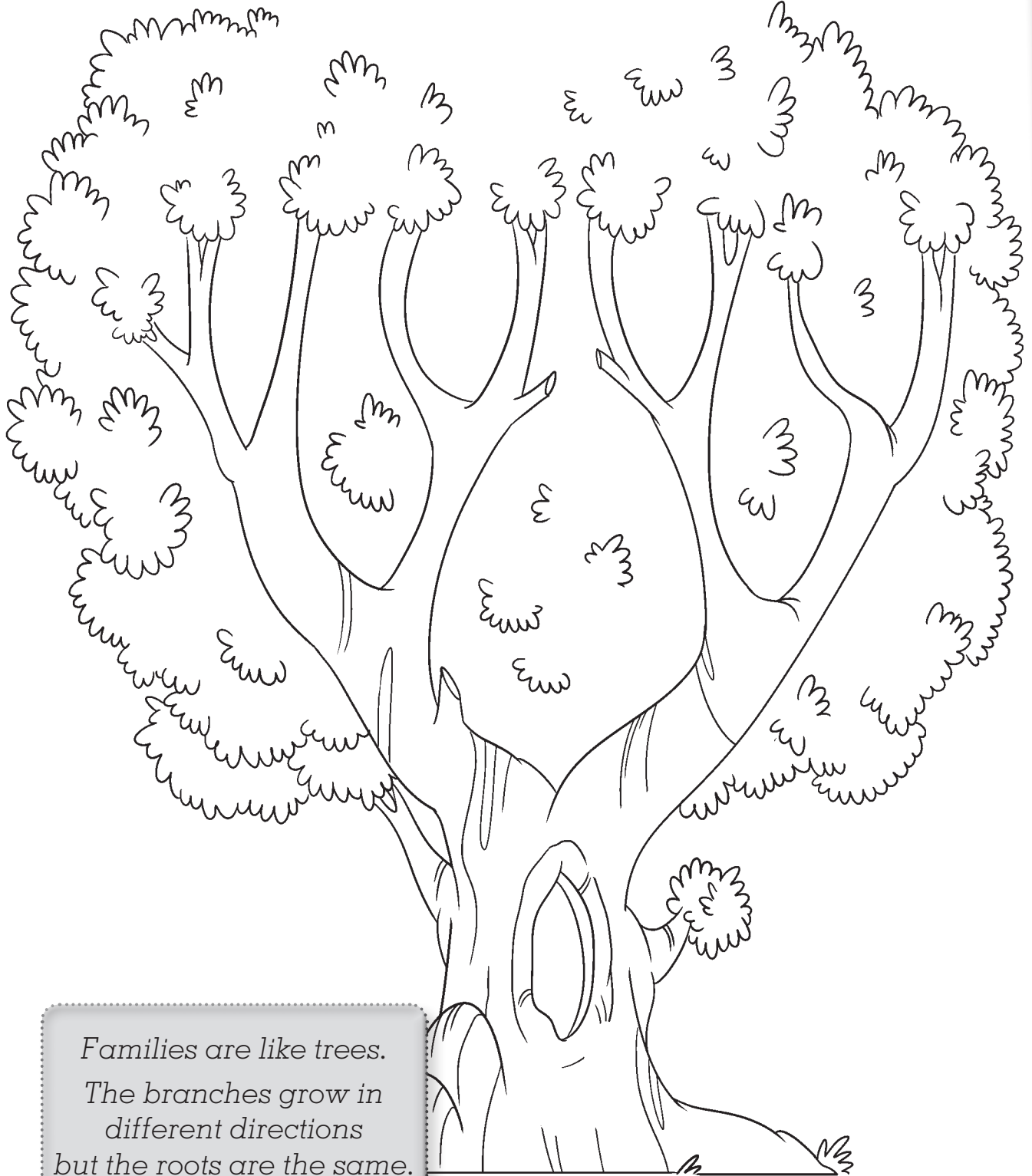

*Families are like trees.
The branches grow in
different directions
but the roots are the same.*

HAPPY ANIMALS

Name

Completa la poesia con i nomi degli animali.

I am a l.....
 I am big and strong.
 I roar and roar
 all day long.

My friend the t.....
 lives with me.
 We are happy.
 We are free.

The g..... and the
 m.....
 are here, too.
 We are happy.
 We aren't in the zoo!

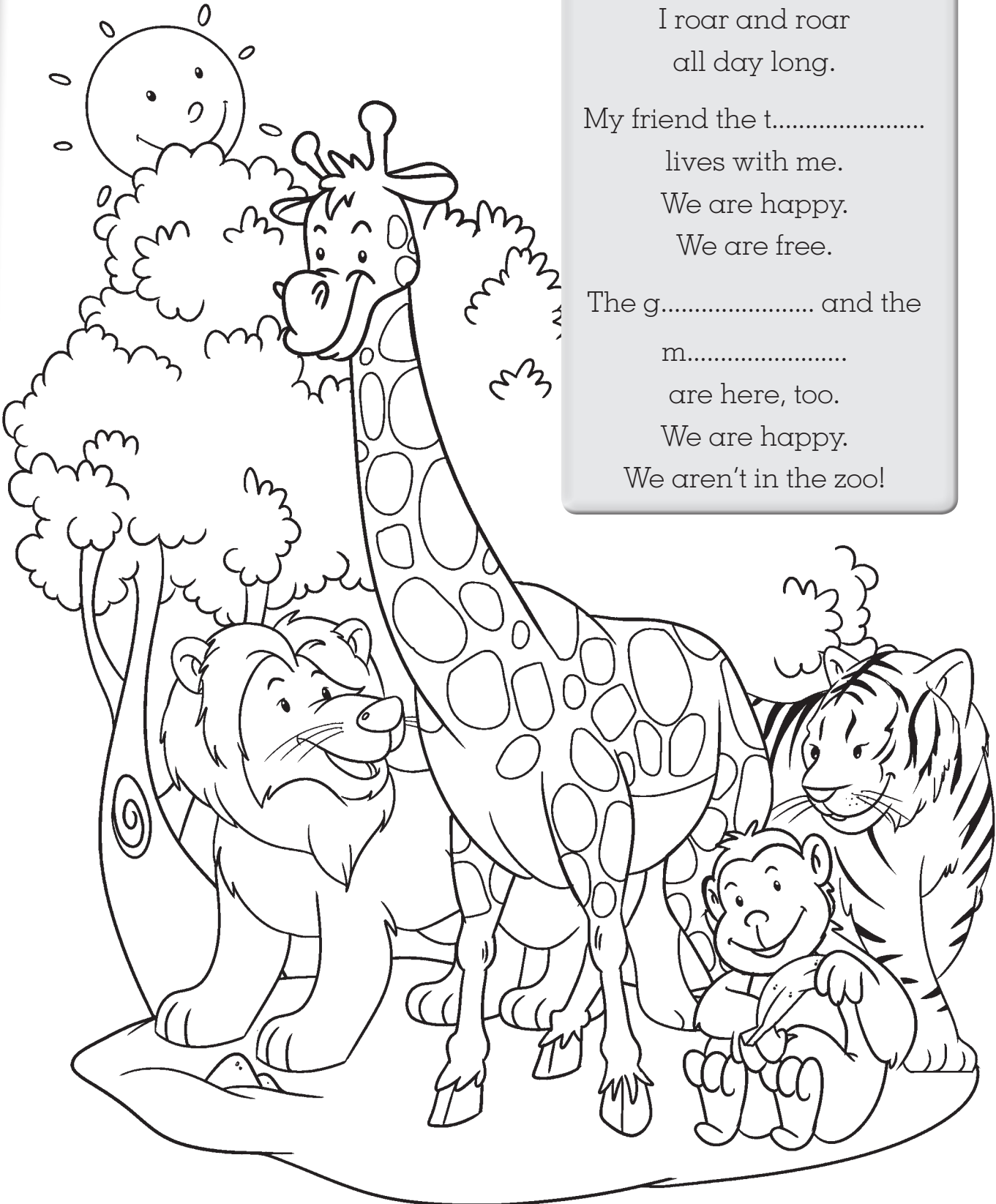

LEVEL 3

MY FRIENDS

Name

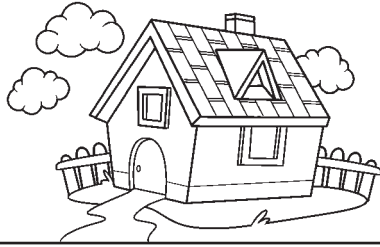

Friends in my neighbourhood

.....

.....

.....

Friends at school

.....

.....

.....

Friends learn,
play and grow
together!



Friends at the park

.....

.....

.....

Friends on holiday

.....

.....

.....

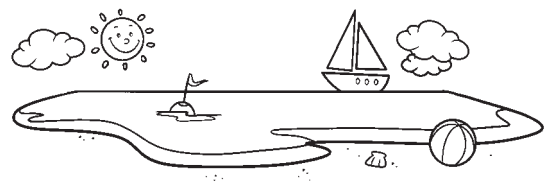
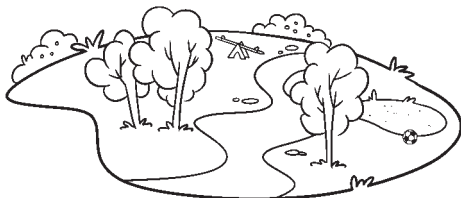

SPORTS

Name

1 Colloca i nomi degli sport sotto gli attrezzi illustrati.

baseball football golf hockey skiing
tennis swimming volleyball

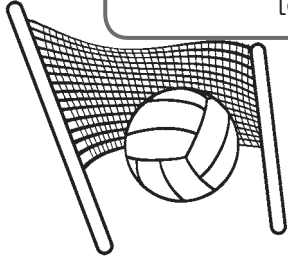

1

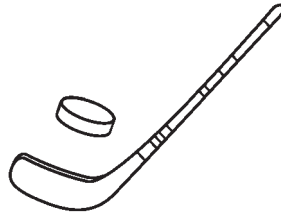

2



3

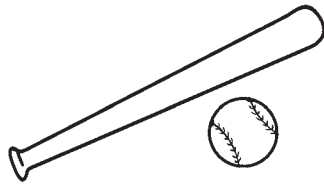

4

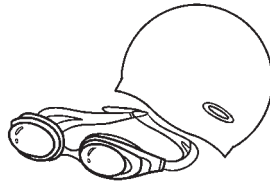

5

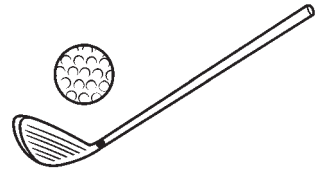

6

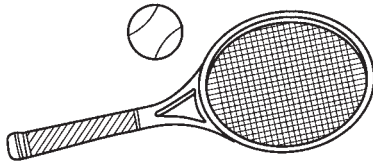

7

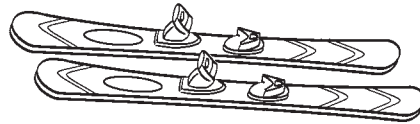

8

2 Scrivi i nomi degli sport preferiti di John, Cathy e Ann.

1 My favourite sport is
.....



2 My favourite sport is
.....



3 My favourite sport is
.....



LEVEL 3

MONSTER VILLE
PUPPETS

Name

Colora, ritaglia e incolla su un bastoncino i personaggi.



LEVEL 3

THE HAUNTED HOUSE

Name

1 Rileggi il racconto sul tuo libro alle pagine 44-45 e osserva le illustrazioni. Poi completa le frasi con *is* oppure *isn't*.

- 1 The haunted house new.
- 2 Lily afraid.
- 3 The haunted house dirty.
- 4 The man in the picture a vampire.
- 5 The cat white.
- 6 The birthday party in the park.



2 Leggi le frasi e numera gli oggetti nella casa stregata che corrispondono alle descrizioni.

LEVEL 3

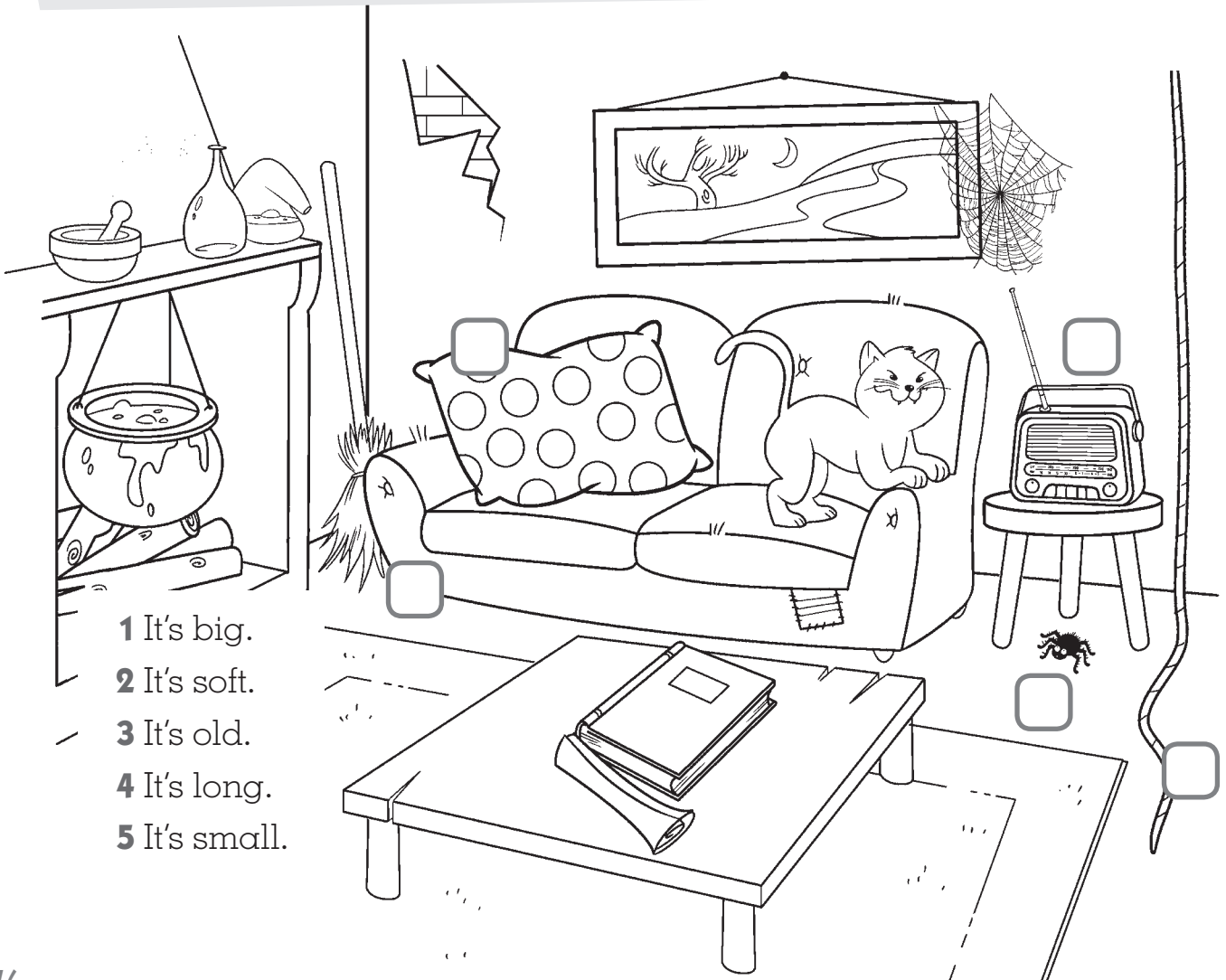

- 1 It's big.
- 2 It's soft.
- 3 It's old.
- 4 It's long.
- 5 It's small.

Name

1 Rileggi il racconto sul tuo libro alle pagine 70-71 e abbinare le frasi ai personaggi che le dicono.

- | | |
|------------------------------|-------|
| 1 I like swimming. | Muzzy |
| 2 I like football. | Oscar |
| 3 I like riding my go-kart. | Wally |
| 4 I am going to the funfair. | Billy |



2 Completa le frasi con *has got* oppure *hasn't got*.

- 1 Oscar a ball.
- 2 Billy a go-kart.
- 3 Wally the homework.
- 4 Muzzy the homework.



LEVEL 3

3 Rileggi ancora e trova nel racconto tre modi per salutare qualcuno quando si va via. Copiali nei fumetti.

1

.....

2

.....

3

.....

BROTHERS AND SISTERS

Name

Raccogli i dati in base alla regola data e annotali qui di seguito. Poi inserisci i dati nei diagrammi.

name	brother	sister
1	<input type="checkbox"/>	<input type="checkbox"/>
2	<input type="checkbox"/>	<input type="checkbox"/>
3	<input type="checkbox"/>	<input type="checkbox"/>
4	<input type="checkbox"/>	<input type="checkbox"/>
5	<input type="checkbox"/>	<input type="checkbox"/>
6	<input type="checkbox"/>	<input type="checkbox"/>
7	<input type="checkbox"/>	<input type="checkbox"/>
8	<input type="checkbox"/>	<input type="checkbox"/>
9	<input type="checkbox"/>	<input type="checkbox"/>
10	<input type="checkbox"/>	<input type="checkbox"/>
11	<input type="checkbox"/>	<input type="checkbox"/>
12	<input type="checkbox"/>	<input type="checkbox"/>

LEVEL 3

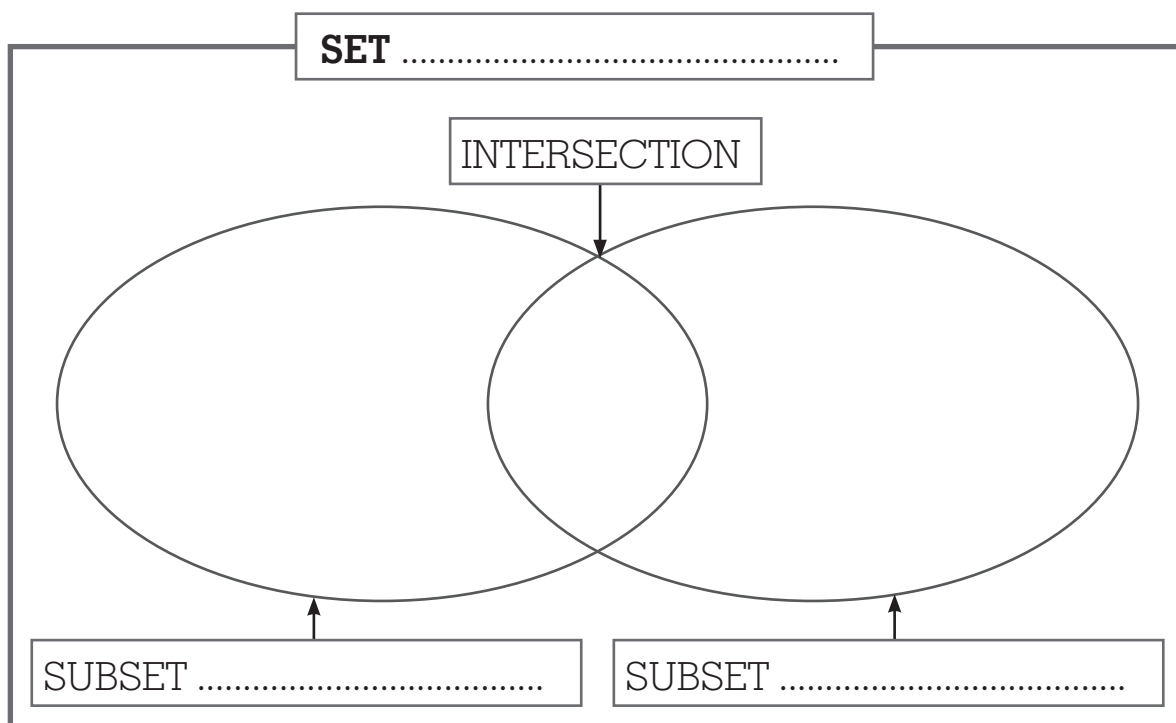

ALL AROUND THE WORLD

Name

Colloca i nomi degli animali nelle frasi giuste e disegnali.

bears whales cows monkeys camels wolves

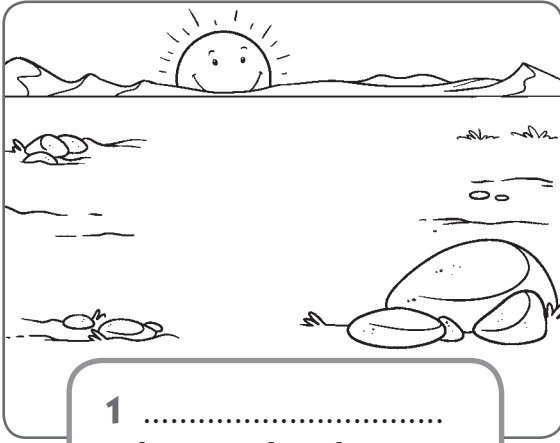

1
live in the desert.

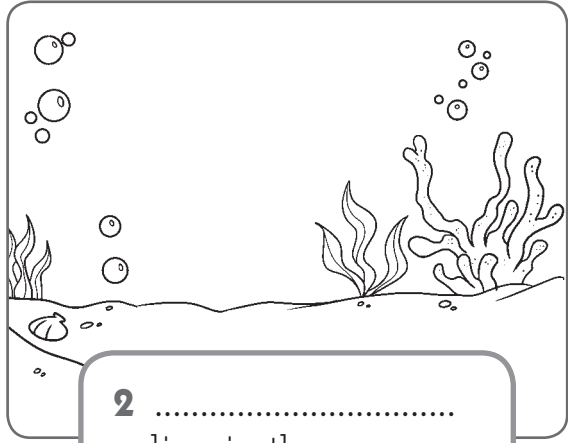

2
live in the sea.

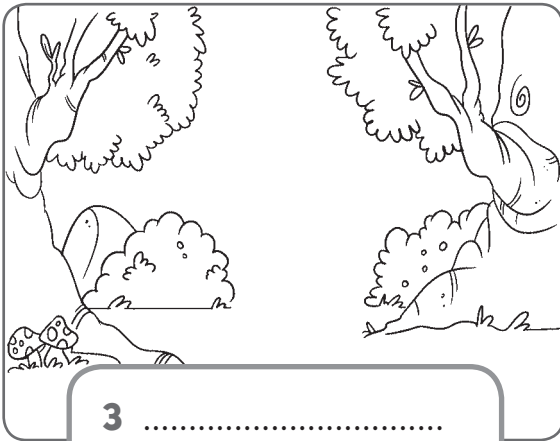

3
live in the forest.

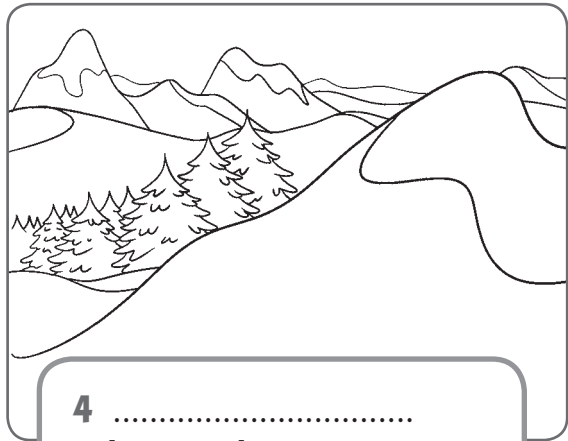

4
live in the mountains.

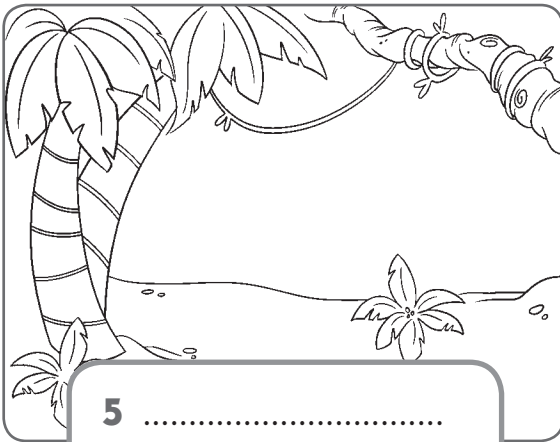

5
live in the jungle.

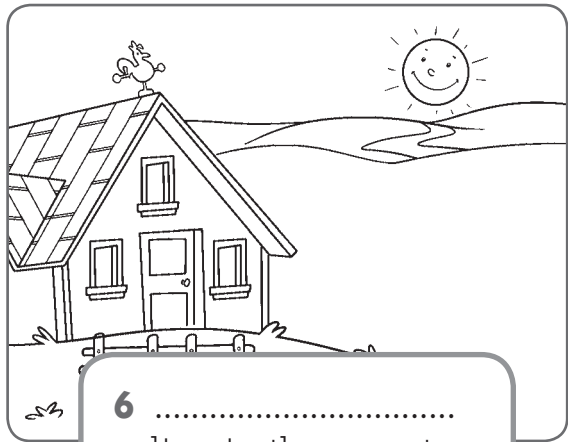

6
live in the country.

RECYCLING

Name

1 Colora la scena che illustra un comportamento corretto.



2 Collega gli oggetti ai contenitori giusti.

newspaper



yogurt container



mirror

PAPER



PLASTIC



tin



ALUMINIUM



GLASS



plastic bottle

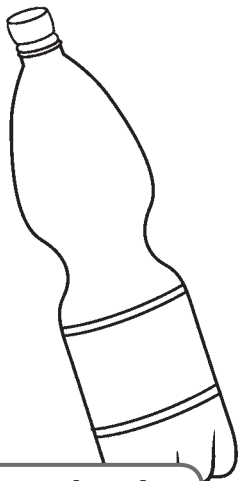

glass



magazine



1 Osserva e leggi. Metti un ✓ se la frase corrisponde al disegno oppure una X.

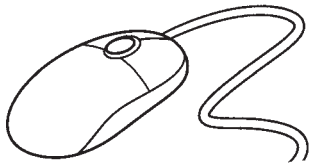

1 This is a mouse.

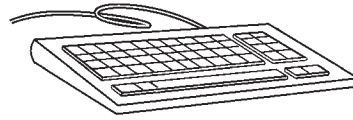

4 This is a keyboard.

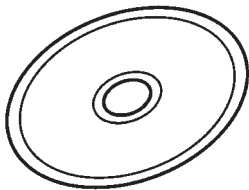

2 This is a scanner.

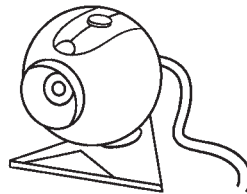

5 This is a monitor.

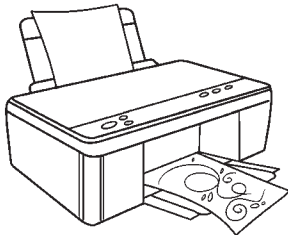

3 This is a printer.

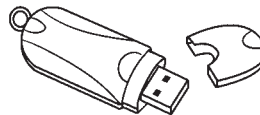

6 This is a USB key.

2 Completa usando le parole fornite.

turn off save print turn on click open write

- 1 the computer.
- 2 on START.
- 3 a file.
- 4 a message.
- 5 the message.
- 6 the message.
- 7 the computer.

PREHISTORIC ANIMALS

Name

1 Completa le frasi con *has got* oppure *hasn't got*.

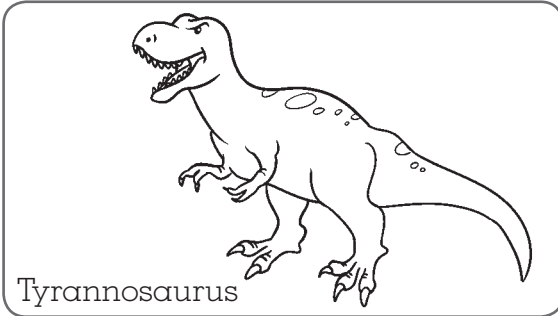

1 It a small body.
It big feet.
It big teeth.

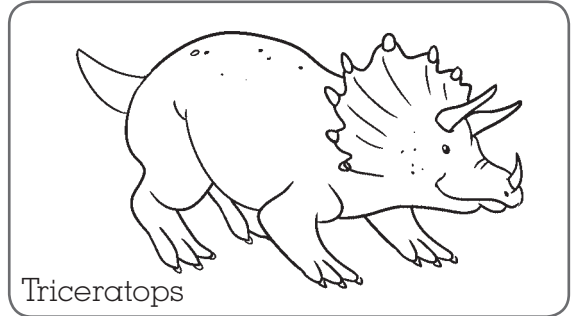

2 It a big head.
It a long tail.
It a big head.

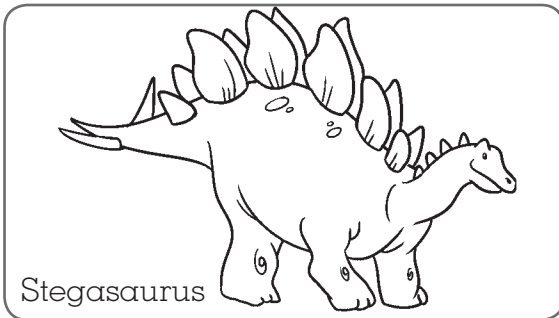

3 It long legs.
It big mouth.
It big ears.

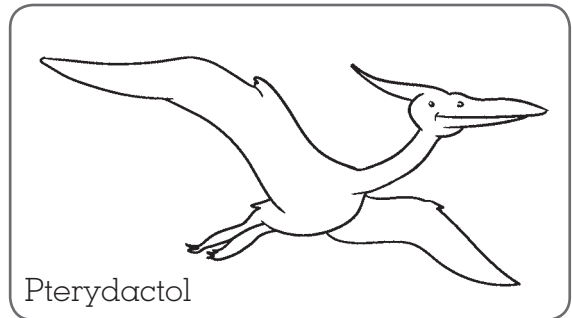

4 It wings.
It big feet.
It small mouth.

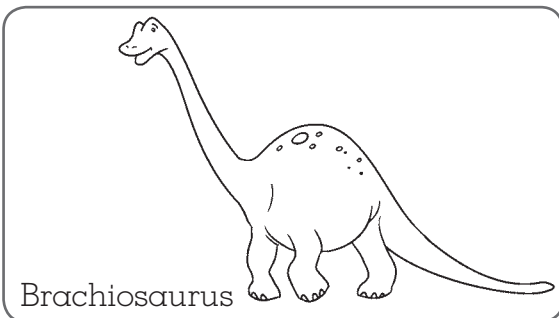

5 It small body.
It long neck.
It long tail.

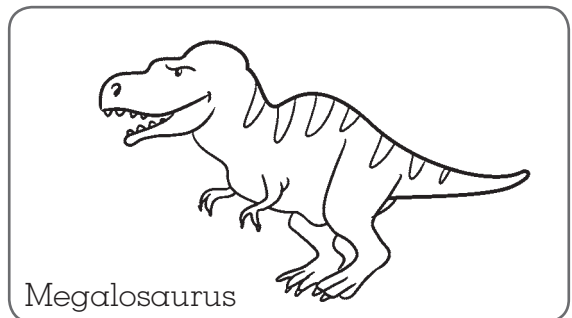

6 It long teeth.
It long arms.
It small feet.

LEVEL 3

1 Di che colore sono? Scrivi e poi colora.



1

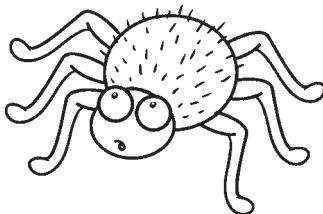

2



3



4

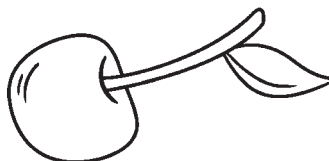

5



6



7

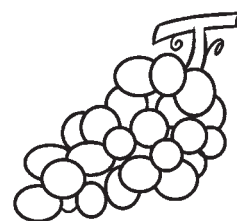

8

2 Esegui i calcoli e scrivi le soluzioni come nell'esempio.

1 $4 + 4 =$ eight

5 $10 - 3 =$

2 $3 \times 2 =$

6 $8 + 4 =$

3 $7 + 3 =$

7 $3 \times 3 =$

4 $8 - 7 =$

8 $6 + 5 =$

3 Riordina le lettere per scrivere i nomi degli oggetti scolastici.

1 nep

5 buerbr

2 obok

6 nhrepsae

3 erlur

7 lbocsghoa

4 ceplni

8 iepcnl aces

1 Leggi le frasi e numera i bambini.
Colora.

- 1 I've got a blue skateboard.
- 2 I've got a red bike.
- 3 I've got a yellow ball.
- 4 I've got a pink scooter.



2 Rispondi in maniera personale.

- 1 Have you got a black bike?
- 2 Have you got a red ball?
- 3 Have you got a brown teddy bear?.....

3 Riordina le lettere scrivendole sotto i disegni.

- 1 cie racem
- 2 trfiu
- 3 etma
- 4 elvseagtbe



1



2



3



4

4 Completa i fumetti con *I like / I don't like* e il nome del cibo illustrato.

1

I
.....

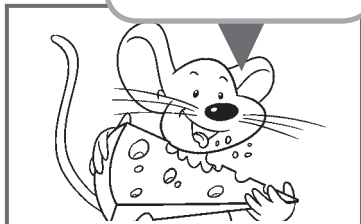

2

I
.....

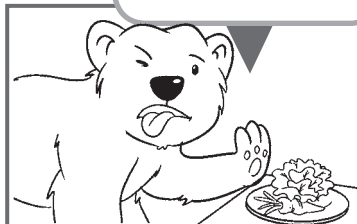

3

I
.....

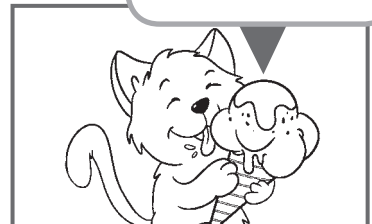

1 Copia i nomi degli animali sotto le illustrazioni giuste.

monkey bear crocodile snake hippo zebra



1



2



3

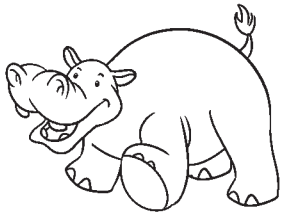

4

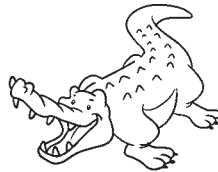

5



6

2 Riordina le lettere e scrivi i nomi dei membri della famiglia.

- 1 eahftr
- 2 rstsie
- 3 tmrhagnerdo
- 4 necul
- 5 mertoh
- 6 herrbto

3 Abbina gli aggettivi, cercando i contrari.

- 1 hard a big
- 2 happy b soft
- 3 small c tall
- 4 dirty d sad
- 5 thin e clean
- 6 short f fat

1 Completa le frasi con la forma affermativa corretta del verbo essere. Cerchia la frase che è illustrata.

- 1 I Italian.
- 2 She tall.
- 3 They pens.
- 4 It a tiger.
- 5 We students.
- 6 You boys.
- 7 He happy.
- 8 They monkeys.



2 Completa il paragrafo con la forma affermativa corretta del verbo essere.

- 1 My name Maria. I Italian.
- 2 I eight years old. I tall and thin.
- 3 In this picture I with my friends Paolo and Linda. We in the mountains.
- 4 Paolo Italian and Linda American.



3 Scrivi le parole al posto giusto e completa le domande. Poi abbinale alle risposte.

it who does they what

- | | |
|------------------------------|------------------------|
| 1 is he? | a He's tall and thin. |
| 2 is it? | b He's Mark. |
| 3 What does look like? | c They're books. |
| 4 What are? | d It's a tiger. |
| 5 What he look like? | e It's small and hard. |

1 Completa i nomi degli oggetti con le lettere mancanti e poi numera i disegni.

1 l..... p..... o p

2 ob..... le p..... o..... e

3 ad..... o

4 vi..... e..... g..... m.....

5 Mp3 la..... er

6 a..... ch

7 c..... l..... ul..... to.....

8 vi..... eo c..... m..... ra

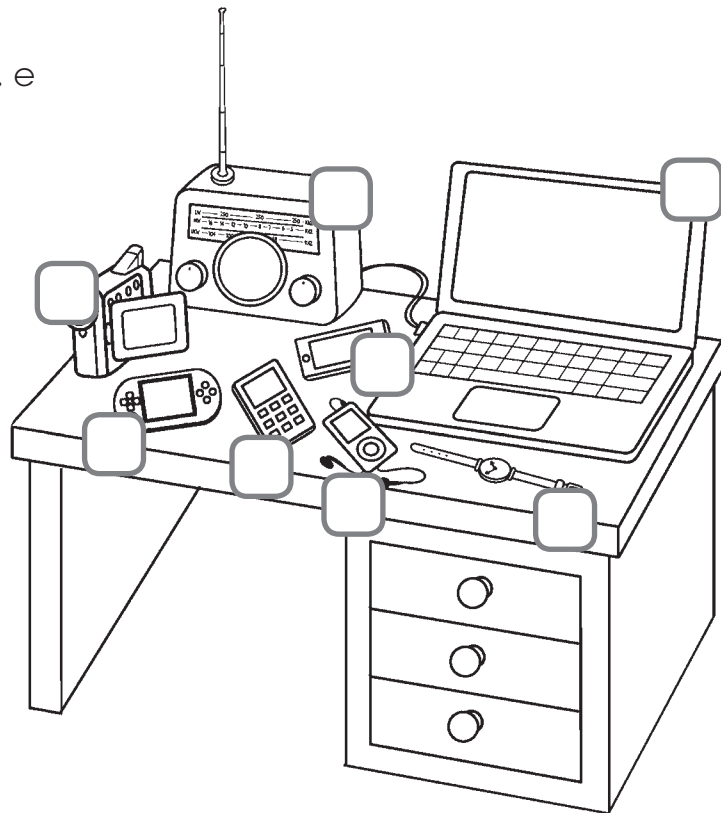

LEVEL 3

2 Cerchia le parti del corpo illustrate.



1 ear / nose



2 mouth / leg



3 finger / toe



4 hand / arm



5 ear / hair



6 foot / arm

1 Completa le frasi con la forma affermativa del verbo avere. Cerchia la frase che è illustrata.

- 1 I a video camera.
- 2 She black hair.
- 3 He a big dog.
- 4 I brown eyes.
- 5 you a cat?
- 6 he a sister?



2 Riscrivi le seguenti frasi nella forma negativa.

- 1 He has got blue eyes.
- 2 I have got a blue ruler.
- 3 She has got long hair.
- 4 Ben has got a sister.

3 Completa le domande con le parole date. Poi abbinale alle risposte.

how got many have has

- | | |
|------------------------------------|-------------------|
| 1 he got a bike? | a Yes, I have. |
| 2 How books have you got? | b No, she hasn't. |
| 3 you got a brother? | c Yes, he has. |
| 4 do you spell your surname? | d B-R-O-W-N. |
| 5 Has she a scooter? | e I've got ten. |

Name

Date Class

1 Ascolta la maestra e indica.



LEVEL 3

2 Adesso ascolta la maestra e colora.

Name

Date Class

3 Abbina le domande alle risposte.

- | | |
|---------------------------------|---------------------------------|
| 1 What colour is it? | a It's number eight. |
| 2 What's your favourite colour? | b It's a ruler. |
| 3 What number is it? | c It's blue. |
| 4 How old are you? | d Yes, I have. |
| 5 How many pencils? | e My favourite colour is green. |
| 6 What is it? | f I'm eight years old. |
| 7 Have you got a teddy bear? | g Seven. |

4 Rispondi alle domande.

1 How old are you?

3 What's your favourite colour?

2 Have you got a bike?

4 Have you got a blue pencil case?



1

3

2

4